



Featuring the iX Series
with **truburn** Flame Technology

SOLUS
ELECTRIC PERFECTION 2025



iX¹⁰ CORNER



iX¹³ FRONT



iX¹⁵ PANORAMIC

INTRODUCTION

| | |
|---------------------------------|--------|
| INNOVATION, DESIGN & CREATIVITY | 5 |
| CONTROLS | 7 |
| SMART TECHNOLOGY | 9 |
| AMBIENT LIGHTING | 11 |
| WARRANTY | 13, 93 |

iX SERIES

| | |
|----------------------------------|---------|
| SOLUS iX COLLECTION | 15 |
| SOLUS iX TECHNICAL SPECIFICATION | 17 |
| iX ¹⁰ | 19 |
| iX ¹³ | 23 |
| iX ¹⁵ | 27 |
| iX ¹⁵ SUITE | 31 |
| iX ¹⁸ | 33 |
| iX APPLIANCE DIMENSIONS | 84 - 88 |
| WARRANTY | 13, 95 |

VS75 PANORAMIC



VS220 CORNER



VS100 ZENITH SUITE



VS SERIES

| | |
|---------------------------------------|---------|
| SOLUS VS COLLECTION | 37 |
| SOLUS VS TECHNICAL SPECIFICATION | 39 |
| COPPICE LOGS | 41 |
| OPTIONAL PLINTHS AND SHELVES | 43 |
| VS75 | 45 |
| VS100 | 49 |
| VS100 NIRA SUITE | 53 |
| VS100 ZENITH SUITE IN CALACATTA | 55 |
| VS100 ZENITH SUITE IN NERO | 57 |
| VS130 | 59 |
| VS150 | 63 |
| MALMO BENCH TO SUIT THE VS150 | 67 |
| VS150 WITH CANOVA PLINTH IN CALACATTA | 69 |
| VS150 WITH CANOVA PLINTH IN NERO | 71 |
| VS150 MEDIA SUITE | 73 |
| VS180 | 77 |
| VS220 | 79 |
| VS APPLIANCE DIMENSIONS | 89 - 91 |
| VS PLINTH & SHELF DIMENSIONS | 92 - 94 |
| WARRANTY | 13, 95 |

ix¹⁰ FRONT





INNOVATION, DESIGN & CREATIVITY.

Innovation, flair and creativity is the driving force behind Solus product development. Our design team is passionate about bringing new and exciting ideas to life by pushing the boundaries of traditional electric appliances with the amalgamation of exquisite styling, cutting edge technologies and innovation to provide instant heat, realistic flames, and adaptive ambient lighting to your living space.

The Solus range is the outstanding result of extensive research and development, meticulous attention to detail, and the highest standard of quality. With a host of unique and innovative features, these appliances are unrivalled in their class.





INSTANT HEAT AT YOUR FINGERTIPS.

Part of the Solus design ethos is to ensure that all appliances offer clear and simple controllability. Whilst functionality may have advanced and become more dynamic, we believe that intuitive interaction is paramount.

The Solus fires can be conveniently controlled in four ways:

- Manually using the multi-function panel discretely located on the appliance
- With the intuitive remote-control handset
- Through your smart device (such as phone or tablet) using Wi-Fi connectivity
- Voice Control*

With built in Wi-Fi connectivity, enhance your user experience with our smart app enabling you to control your appliance from anywhere! The app allows you to set tailored programmes, schedule on/off times, set temperatures, design custom light effects, plus much more.

The quick start heat option allows you to select low heat, high heat, or cool blow at the touch of a button. Whilst adaptive smart heating allows you to schedule the exact time and date you wish to heat your room, automatically adjusting the environment to reach and maintain the desired temperature.

*Available on iX models only. The voice control for VS is limited to turning on and off only.





SMART TECHNOLOGY.

With Solus, the combination of functionality through applied smart technology, it creates the ultimate home heating experience. Your appliance will synchronise with your smart device, such as phone or tablet, putting you in complete control. The latest sensor technology helps to create our most efficient appliance ever, ensuring that the room is heated to the correct temperature at the correct time with optimum energy usage.

We are committed to a sustainable future, ensuring that our appliances make the most efficient use of energy. All Solus appliances benefit from temperature detection and regulation technology; if there is a sudden drop in room temperature, perhaps caused by an open window or door, the appliance will temporarily deactivate any heating functions to avoid energy wastage and will reactivate when the window or door is closed.

VS100 ZENITH IN NERO





OPTIONAL AMBIENT LIGHTING.

Extend the atmosphere beyond the fire and into the room using a Solus ambient lighting kit, allowing you to create a further interactive dimension to the environment. This additional lighting features 15 colour modes and can be controlled by the appliance remote control or the via your smart device. The kit features a 3 metre length of RGB LED strip light and up to two kits can be simultaneously connected to a Solus appliance, making it the perfect addition to fire suites and media walls.



ix¹⁰ CORNER





6 YEAR COMPREHENSIVE WARRANTY.

The Solus Collection: A Legacy of Excellence

For over 70 years, the Solus Collection has exemplified unmatched excellence in the fireplace industry. By seamlessly blending traditional craftsmanship with modern design, we have created uniquely stylish and functional products of the highest quality. Each Solus appliance reflects our unwavering commitment to quality excellence, meticulous attention to detail, and superior craftsmanship, ensuring you can choose Solus with confidence.

Our Warranty: A Promise of Quality

Every Solus appliance comes standard with a comprehensive 6-year warranty (parts & labour), provided it is purchased through an authorised dealer. This warranty underscores our dedication to delivering not just exceptional products, but also peace of mind. For appliances purchased outside our authorised dealer network, a statutory 1-year non-extendable warranty applies.

For full details and terms and conditions, please visit visionfires.co.uk.

iX¹⁵ CORNER





SOLUS iX SERIES

Featuring **truburn** Flame Technology

Taking electric fires to a whole new level, the iX series features Truburn flame technology, bringing electric fires to life like never before. Designed in-house using innovative techniques to create authentic moving flames, ultra realistic glowing logs and authentic sounds effects to produce a convincing illusion a burning fire. The level of realism is truly unparalleled.

The appliances feature a uniquely designed log arrangement, produced to specifically work in conjunction with an intricately created flame pattern that maps the contour of the logs. Each appliance comes with the option to install in a Front, Corner or Panoramic aspect.

- REAL GLOW LOGS
- ECO MODE
- 1.8KW HEAT
- COOL BLOW
- AUDIO FX



Seeing is believing.
Scan the QR code for a video experience that will change the way you think about electric fires.

iX¹⁵ PANORAMIC





iX SERIES

Technical Specification

- New ultra-realistic flame effect with options for flame colour, flame type & flame height
- New feature to add smoke and sparks effect
- Flame effect can be operated with or without heat function
- Dynamic fuel bed featuring our most realistic logs yet, with internal dynamic illumination to mimic charring/glow
- Independent control of illumination for fuel bed, logs and downlight with colour change and brightness settings
- Realistic sounds with advanced speaker
- Easy to use remote control handset
- Easy to use App, controlled via your smart device
- 9 fuel bed colour options
- 'Favourite' mode to save your preferred flame/fuel bed settings
- 2 heat settings - 0.9kW & 1.8kW
- Cool blow function
- Thermostatic control
- Hourly timer mode
- 7-day programmable timer with adaptive smart heating
- Open window detection mode for optimised energy efficiency
- Solus Ambient Light Kit compatible (available as an optional additional purchase)





SOLUS iX¹⁰

Featuring **truburn** Flame Technology

Introducing the Solus iX¹⁰, our cutting-edge electric fire, celebrated for its incredibly realistic flame effect. This innovative appliance creates a convincing visual experience, delivering an enchanting ambiance with its lifelike flames.

With its considered design and advanced features, the Solus iX¹⁰ not only enhances the aesthetic of your space but also delivers efficient heating with just a touch of a button. The Solus iX¹⁰ can be installed in a front, corner, or panoramic configuration, allowing you to choose the perfect setup for your interior. Discover the allure and warmth of the Solus iX¹⁰, making it an exceptional choice for sophisticated interiors.

iX¹⁰ FRONT



For those seeking a bolder aesthetic, the iX¹⁰ features the eye-catching Manhattan trim as an optional extra. Detailed from a reassuringly heavy gauge, extruded aluminium, this four-sided fascia creates a sleek, yet intentional frame to showcase the mesmerising focal point within. The Manhattan trim is easy to install and provides the perfect finishing touch to any installation.

iX10 CORNER



iX10 PANORAMIC



iX¹³ CORNER





SOLUS iX¹³

Featuring **truburn** Flame Technology

Presenting the Solus iX¹³, our advanced electric fire known for its astonishingly realistic flame effect. This state-of-the-art appliance offers an enchanting visual experience, creating a captivating ambiance with its lifelike flames.

The Solus iX¹³ boasts a sleek design and cutting-edge features, enhancing the aesthetic of your space while providing efficient heating at the touch of a button. The Solus iX¹³ can be installed in a front, corner, or panoramic configuration, allowing you to choose the perfect setup for your interior. Discover the beauty and warmth of the Solus iX¹³ and see why it's the perfect choice for elegant and sophisticated interiors.

iX¹³ PANORAMIC



iX¹³ FRONT



iX¹³ CORNER



ix¹⁵ FRONT





SOLUS iX¹⁵

Featuring **truburn** Flame Technology

The Solus iX¹⁵ is our premium electric fire, renowned for its ultra-realistic flame effect. This state-of-the-art electric fire offers an exceptional visual experience, creating a captivating ambiance with its lifelike flames.

With its sleek design and advanced features, not only does the Solus iX¹⁵ enhance the look of your space but it also provides efficient heating at the touch of a button. Discover the beauty and warmth of the Solus iX¹⁵ and see why it's a standout choice for refined interiors.

iX¹⁵ CORNER



iX¹⁵ PANORAMIC



iX¹⁵ FRONT



For those seeking a bolder aesthetic, the iX¹⁵ features the eye-catching Manhattan trim as an optional extra. Detailed from a reassuringly heavy gauge, extruded aluminium, this four-sided fascia creates a sleek, yet intentional frame to showcase the mesmerising focal point within. The Manhattan trim is easy to install and provides the perfect finishing touch to any installation.

iX¹⁵ MEDIA SUITE





iX¹⁵ MEDIA SUITE.

Featuring **truburn** Flame Technology

The pinnacle of luxury in premium electric fires, celebrated for its ultra-realistic flame effect. Now featuring the Cupria Stone and White media suite, it combines a warm, grey/copper-coloured base with a striking, opaque white lacquered finish. This refined suite elevates any home with sophistication and natural charm.

Experience the state-of-the-art visual delight of the iX¹⁵ as its lifelike flames create a captivating ambiance. The classic lines and sleek design of the iX¹⁵ Suite not only enhance your living space's elegance but also provide efficient heating at the touch of a button.

Discover the allure and comfort of the Solus iX¹⁵, a standout choice for those with a taste for refined interiors. Unveil an exceptional visual experience and enchant your home with its unique charm.







SOLUS iX¹⁸

Featuring **truburn** Flame Technology

Introducing the Solus iX¹⁸, the largest and most impressive fire in the iX Series. This state-of-the-art electric fire is renowned for its astonishingly realistic flame effect, delivering a mesmerising visual experience with lifelike flames that create a warm, inviting ambiance.

With its considered design and advanced technology, the Solus iX¹⁸ will enhance any space it occupies and provide efficient heating at the touch of a button. You can install each Solus iX¹⁸ appliance in a front, corner, or panoramic configuration, giving you the flexibility to perfectly match your interior setup. Experience the unmatched beauty and warmth of the Solus iX¹⁸, the ultimate choice for those seeking elegance and sophistication in their homes.

iX¹⁸ FRONT



iX¹⁸ CORNER



iX¹⁸ PANORAMIC



VS180 CORNER





SOLUS VS SERIES

Whether you are planning on creating the ultimate social hub or simply increasing the wow-factor of your living room, make every detail matter with a Solus appliance from Vision Fires. Our approach is to create beautiful, inspiring appliances that change the perception of a traditional electric fire.

With a Solus fire, you are in control of every aspect of your appliance, from the speed, colour and brightness of the entrancing flames to the enchanting crackling sounds of burning logs, or the complementing ambient lighting of your extended living space.

Our unique TriLight technology provides multi angled, fully customisable dynamic LED lighting to create thousands of unique colour and tonal combinations to the flames and fuel bed. Each can work in harmony with one another or can work independently to create a unique combination to create a truly unique atmosphere, all at the touch of a button.

To provide an insight into the possibilities, all Solus fires come with 6 programmed themes to highlight some of the fascinating lighting combinations that can be created. Please see the VS technical specification on page 39 for more information.

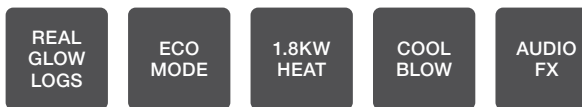

Seeing is believing.
Scan the QR code for a video experience that will change the way you think about electric fires.

VS220 CORNER





VS SERIES

Technical Specification

Create something truly breath-taking with a Solus appliance. Space enhancing, stylish and practical, our appliances are available in a range of shapes and sizes that can be fitted to your exact specification.

- Realistic flame effect that can be operated with or without heat function
- Dynamic fuel bed featuring realistic logs
- Easy to use remote control handset
- Easy to use App, controlled via your smart device.
- Variable flame speed
- 9 flame effect colour options
- 9 fuel bed colour options
- 'Favourite' mode to save your preferred flame/fuel bed settings
- 2 heat settings - 0.9kW & 1.8kW
- Cool blow function
- Thermostatic control
- Hourly timer mode
- 7-day programmable timer with adaptive smart heating
- Open window detection mode for optimised energy efficiency
- Option for ambient lighting kit

Solus fires come with 6 programmed themes:



COPPICE REAL LOG SET TO SUIT
LANDSCAPE VS MODELS





FOR THE ULTIMATE IN PERFECTION, LOOK TO NATURE!

Introducing the Coppice real log set, the definitive upgrade for your Solus VS Series appliance. Offering the ultimate in realism, this hand-crafted piece uses specially selected, natural logs to create an authentic latticed fuel bed, complete with forest floor embers. Every Coppice real log set is unique and produced in the UK using locally sourced materials, expertly bonded together to form a single, easy to install product that adds the perfect finishing touch to your fire.

Our Coppice Real Log sets are crafted using natural products and there may be some variances between each fuel bed. We always aim to reproduce the same layout for each set but due to the nature of the products being used there may be variances in the finer details.



VS100 PANORAMIC WITH ANTHRACITE SHELF





OPTIONAL PLINTHS AND SHELVES

Indulge in the epitome of luxury with our exclusive range of versatile plinths and shelves, meticulously designed to complement the distinguished VS100 and VS150 series. Impeccably crafted from the finest materials, these exquisitely formed pieces embody timeless elegance and sophistication, enhancing the ambiance of any living space.

The highly adaptable plinths and shelves offer the ultimate in customisation, allowing you to mix and match to create a truly bespoke experience. For a closer look at these refined options, refer pages 49 and 65 to 67.

VS75 PANORAMIC





VS75.

The VS75 is a versatile fire, perfectly at home in a contemporary setting or more traditional environments. The large glass viewing panel is perfectly suited for use with our modern furniture elements or with a complementing fireplace mantel, bringing a welcome sense of grand stature.

Coppice Real Log upgrade available on this appliance see page 41 for details.

VS75 FRONT





VS75 FRONT



VS75 CORNER



VS100 CORNER





VS100.

Add luxury to your living space with the VS100, the ultimate home investment. The VS100 is the smallest of our landscape electric fires at 1 metre in length. With an option of inset, panoramic or corner aspect you will be spoilt for choice when creating your perfect fireplace.

A range of versatile plinths and shelves are available to compliment the VS100. They are flawlessly constructed from high quality materials. The classical crafted lines are a beautiful way to enhance any living space. The highly versatile plinths and shelves allow you to mix and match to suit your requirements. See page 43 for examples or please ask your approved stockist for details.

Coppice Real Log upgrade available on this appliance see page 41 for details.

VS100 PANORAMIC WITH SHELF



VS100 CORNER



VS100 PANORAMIC



VS100 PANORAMIC WITH SHELF AND PLINTH



VS100 NIRA SUITE





VS100 NIRA SUITE.

The epitome of luxury, this suite is designed exclusively for the VS100 electric fire. The striking light grey Chicago concrete effect sections, a staple in high-end interior design, seamlessly blends with the contemporary charm of the white top and bottom sections.

Crafted from high-quality materials, the VS100 Nira Suite showcases authentic concrete effect textures that amplify the aesthetic appeal of any home. Its classically crafted lines bring a refined elegance to your living environment, transforming your space into a luxurious haven.

Experience the exquisite beauty of the VS100 Nira Suite, where luxury meets functionality. For those with a discerning eye, the VS100 Nira Suite paired with the VS100 electric fire is an unparalleled choice for refined interiors.

Coppice Real Log upgrade available on this appliance see page 41 for details.



VS100 ZENITH SUITE IN CALACATTA





VS100 ZENITH SUITE IN CALACATTA.

The classical lines of the VS100 Zenith Suite are a beautiful way to enhance any living space. Crafted from Calacatta Honed Sintered Stone, this wonderfully appealing material utilises cutting edge technology to create an irresistible alternative to marble or quartz. The process of sintering takes natural mineral particles and forms them under incredible heat and pressure to produce a strong and durable material that is resistant to scratching, can withstand high temperatures, does not deteriorate, or discolour from UV rays, and is very easy to clean. Calacatta Honed Sintered Stone is an authentically accurate recreation of Calacatta marble with simple grey veining, adding depth to the smooth white finish that just begs to be touched.

Coppice Real Log upgrade available on this appliance see page 41 for details.

VS100 ZENITH SUITE IN NERO





VS100 ZENITH SUITE IN NERO.

The classical lines of the VS100 Zenith Suite are a beautiful way to enhance any living space. Crafted from Nero Honed Sintered Stone, the striking aesthetic of this distinctive material is marked by uniqueness. The Nero offers a fully inverted appearance with an abundance of white veining against a deep black marble.

Demonstrating decades of manufacturing excellence, careful consideration has been taken to ensure alignment of the inimitable veining patterns across each component, creating a sense of continuity that conveys affluence and luxury.

Coppice Real Log upgrade available on this appliance see page 41 for details.

VS130 PANORAMIC





VS130.

At 1.3 metres in length, the VS130 is ideal for a range of interiors with its minimalist design themes. Add a sense of wonder to your home and bring it to life with the touch of a button.

Coppice Real Log upgrade available on this appliance see page 41 for details.

VS130 PANORAMIC



VS130 FRONT



VS130 CORNER



VS150 PANORAMIC





VS150.

Whether you want to update or build a contemporary dream home, the VS150 will transform any room with a sense of luxury. This fire is 1.5 metres in length and can be installed in either inset, panoramic or corner aspect allowing you full creative control.

A range of versatile plinths and shelves are available to compliment the VS150. They are flawlessly constructed from high quality materials. The classical crafted lines are a beautiful way to enhance any living space. The highly versatile plinths and shelves allow you to mix and match to suit your requirements.

Coppice Real Log upgrade available on this appliance see page 41 for details.

VS150 FRONT



VS150 FRONT



VS150 CORNER





VS150

MALMO BENCH TO SUIT THE VS150





MALMO BENCH TO SUIT THE VS150.

Introducing the Malmo, a masterclass in classic design and retro charm. The Malmo combines timeless design elements to create a captivating bench that stands out in any space. Its warm and rich walnut veneer is skilfully complemented by the delicate yet strong hairpin legs, showcasing a harmonious blend of form and function. This piece embodies elegance and sophistication, making it a perfect addition to both modern and traditional interiors. The Malmo is not just a piece of furniture; it's a statement of style and a testament to exceptional craftsmanship. Elevate your living space with the Malmo and experience the perfect fusion of aesthetics and practicality.

Paired with the VS150 Malmo appliance, this ensemble offers both visual and practical enhancements to your home. The VS150 Malmo fireplace complements the bench with its sleek, contemporary design, customizable flame settings, and energy-efficient performance. Together, they create a cohesive and stylish ambiance, transforming any living space into a haven of luxury and comfort. Enjoy the synergy of form and function with the Malmo bench and VS150 Malmo fireplace, where elegance meets innovation.

VS150 WITH CANOVA PLINTH IN CALACATTA





VS150 WITH CANOVA PLINTH IN CALACATTA.

The Canova Plinth, designed specifically for the Solus VS150 electric fire. This sleek and stylish plinth enhances the visual appeal of your electric fire, providing a sophisticated and modern base that complements the elegant design of the Solus VS150.

Crafted with precision and attention to detail, the Canova Plinth offers a seamless integration that elevates your home's décor while adding a touch of luxury.

Elevate your fireplace experience with the new Canova Plinth and transform your space with contemporary elegance.

Coppice Real Log upgrade available on this appliance see page 41 for details.



VS150 WITH CANOVA PLINTH IN NERO





VS150 WITH CANOVA PLINTH IN NERO.

The Canova Plinth in Nero is designed specifically for the Solus VS150 electric fire. This sleek and stylish plinth enhances the visual appeal of your electric fire, providing a sophisticated and modern base that complements the elegant design of the Solus VS150.

Crafted from Nero Honed Sintered Stone, the striking aesthetic of this distinctive material is marked by uniqueness. The Canova Plinth offers a seamless integration that elevates your home's décor while adding a touch of luxury. The Nero offers a fully inverted appearance with an abundance of white veining against a deep black marble. Demonstrating decades of manufacturing excellence, careful consideration has been taken to ensure alignment of the inimitable veining patterns across each component. Elevate your fireplace experience with the new Canova Plinth and transform your space with contemporary elegance.

Coppice Real Log upgrade available on this appliance see page 41 for details.



VS150 MEDIA SUITE IN CUPRIA STONE





VS150 MEDIA SUITE.

Indulge in the epitome of modern elegance with the VS150 Media Suite, available in Cupria Stone, White, or a striking combination of both.

- Cupria Stone: This option boasts a warm, natural charm with its copper-coloured base, enhancing the rich black stone effect. Perfectly complemented by bronze, copper, or red wood tones, the Cupria Stone brings a sophisticated touch to any home.
- White: The neutrality of the white finish creates a striking contrast. It provides the effect of an opaque white lacquer, resulting in a natural finish.

The classic lines of the Media Suite offer timeless beauty, designed specifically to suit the VS150 appliance. With a sleek design, this media suite provides an unrestricted view of the mesmerising fire from every angle in the room, all at the touch of a button.

Elevate your interior with the unparalleled refinement of the VS150 Media Suite and experience the captivating ambiance it brings to your living space.

Coppice Real Log upgrade available on this appliance see page 41 for details.

VS150 MEDIA SUITE IN WHITE



VS150 MEDIA SUITE IN CUPRIA STONE

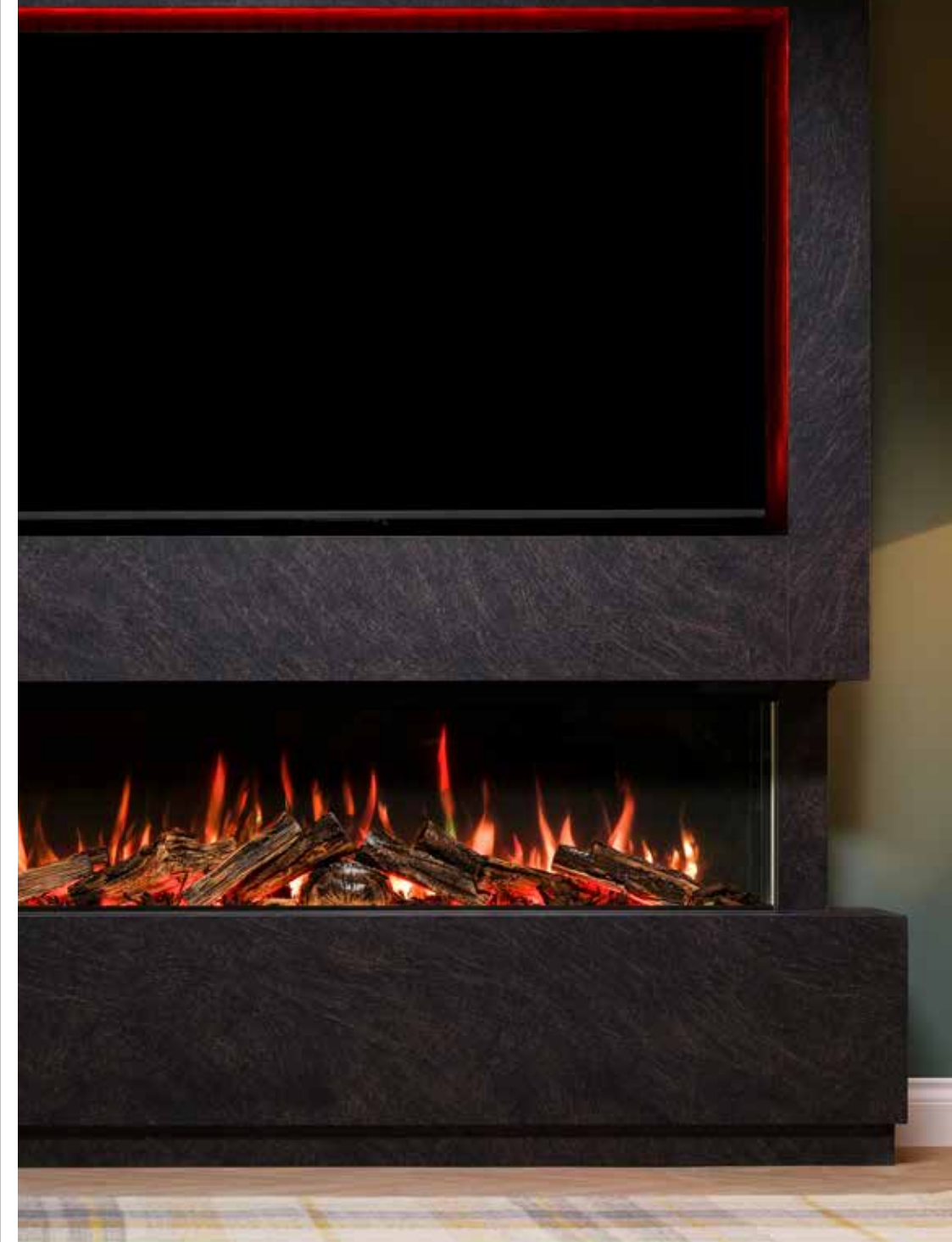

VS150 MEDIA SUITE IN CUPRIA STONE AND WHITE PLINTH



VS150 MEDIA SUITE IN WHITE AND CUPRIA STONE PLINTH



VS180 CORNER





VS180.

When you really want to create an impression, the VS180 really makes an impact. At 1.8 metres in length, this is sure to create an eye-catching centrepiece to any room.

Coppice Real Log upgrade available on this appliance see page 41 for details.

VS180 PANORAMIC





VS220 CORNER





VS220.

At 2.2 metres in length, the VS220 is the largest fire in the Solus Collection. This elegantly styled landscaped electric fire will fit seamlessly in a range of interiors. It's particularly suited to modern interior design styles. As impressive as it is, you are still in control of every aspect of the fire, from the speed, colour, and brightness of the captivating flames to the enchanting crackling sounds of burning logs.

Coppice Real Log upgrade available on this appliance see page 41 for details.

VS220 PANORAMIC



VS220 FRONT



VS220 FRONT



iX APPLIANCE DIMENSIONS.

All dimensions are in millimetres.

iX¹⁰ Panoramic/Corner

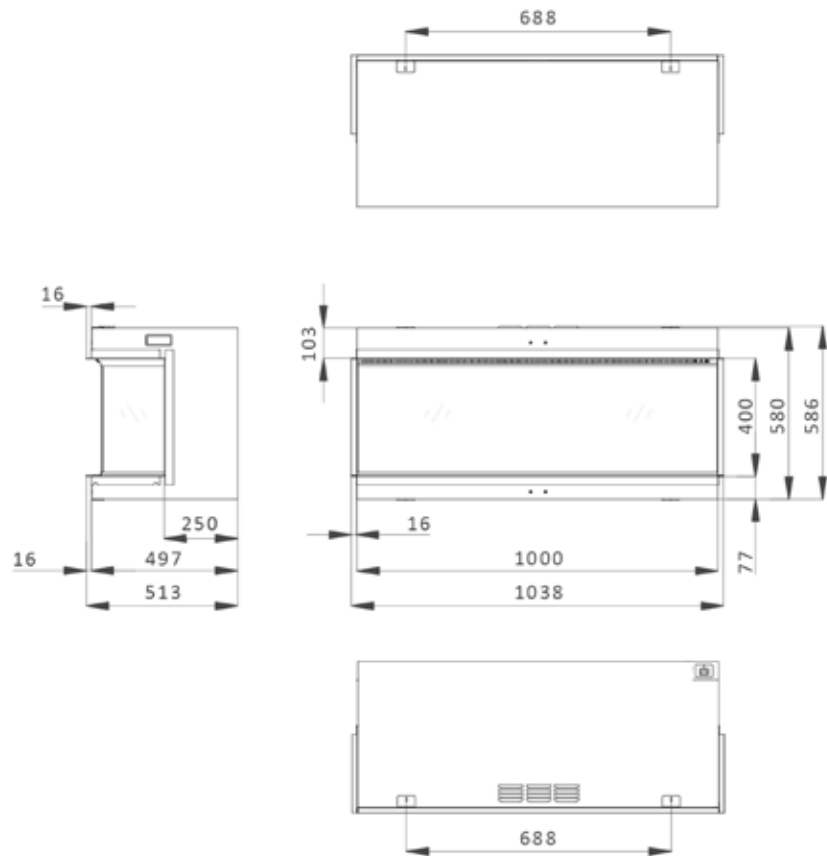

iX¹⁰ Front

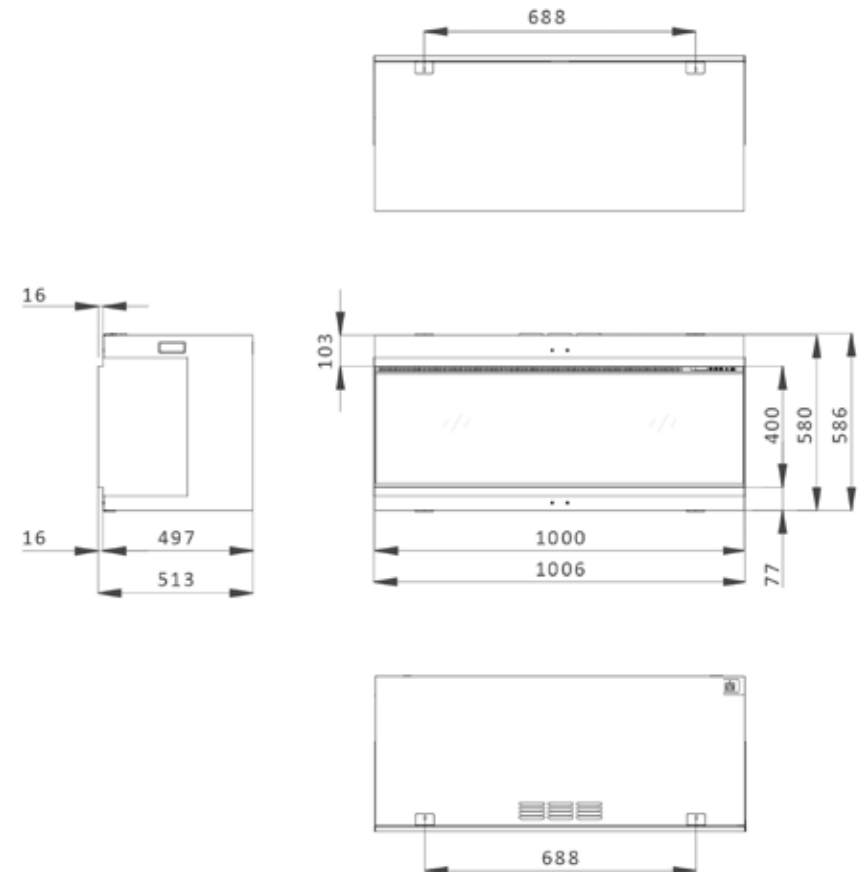

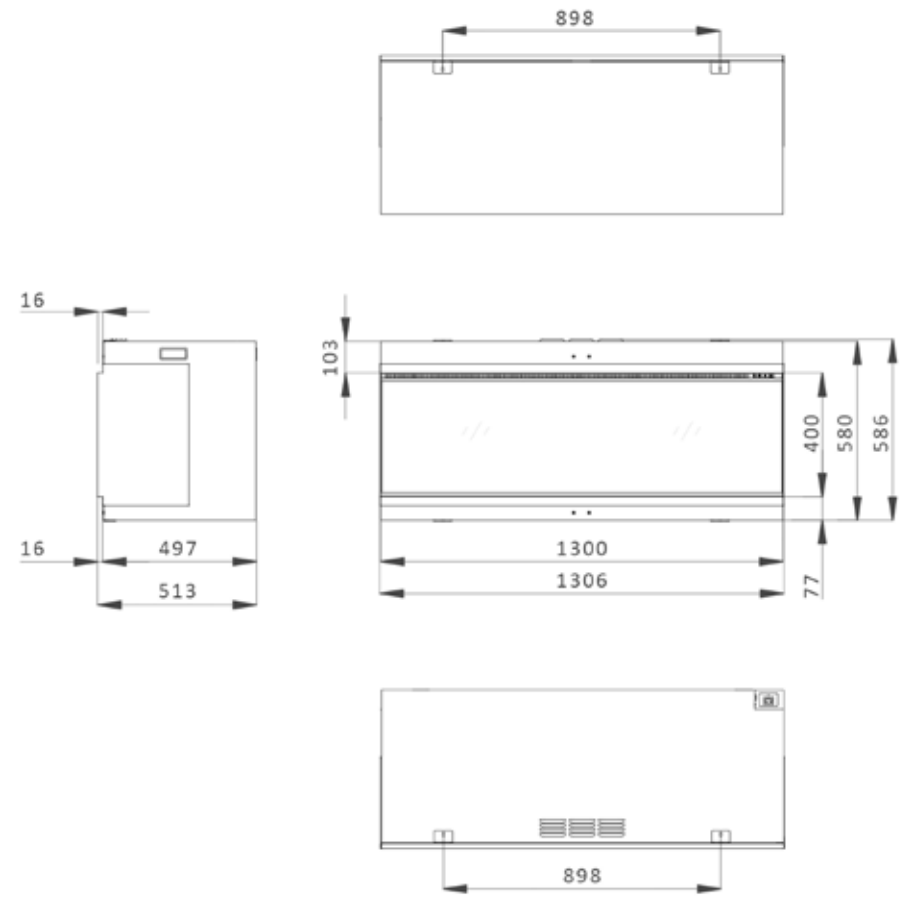
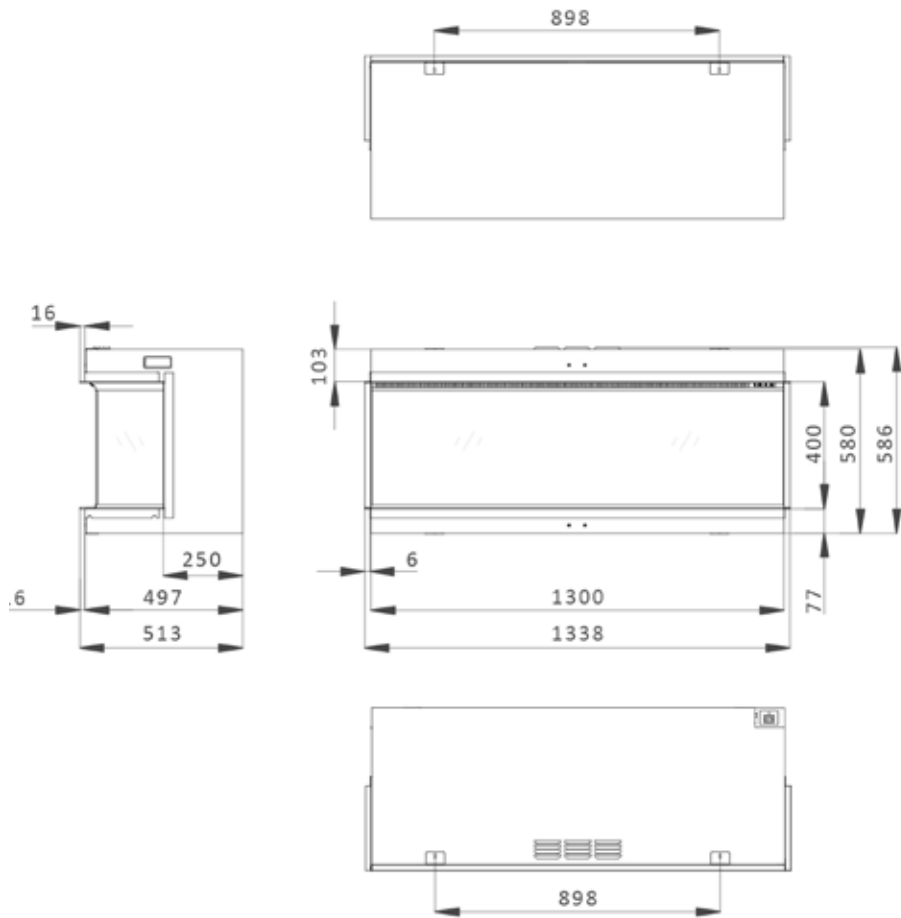

iX APPLIANCE DIMENSIONS.

All dimensions are in millimetres.

iX¹⁵ Panoramic/Corner

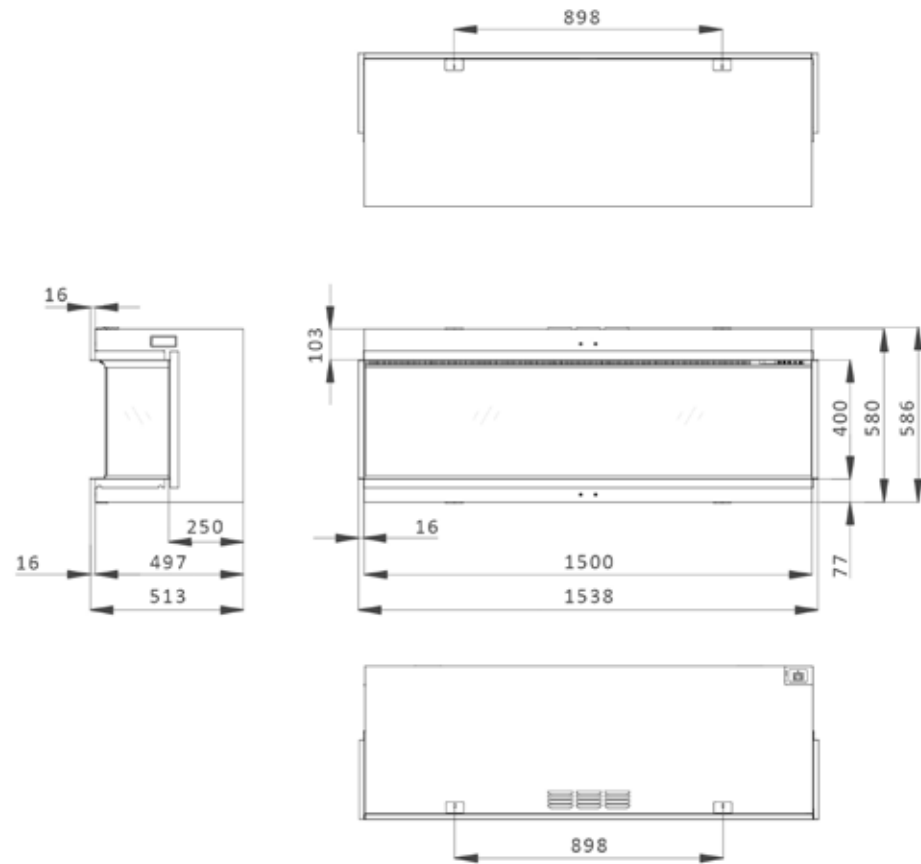

iX¹⁵ Front

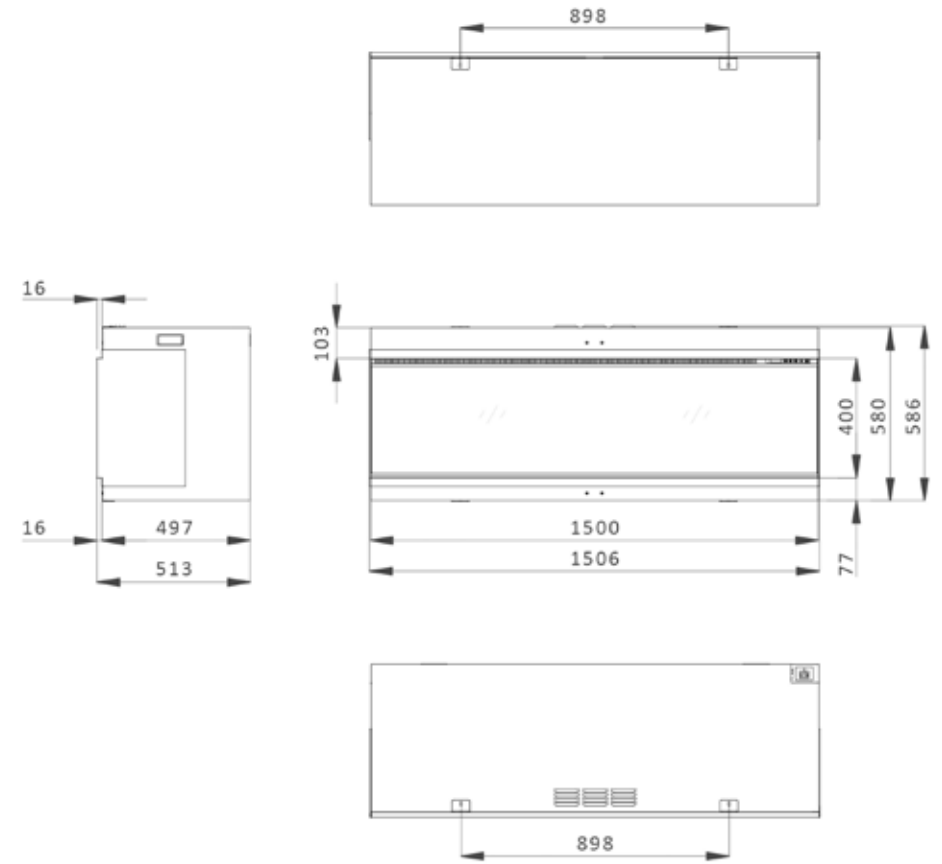

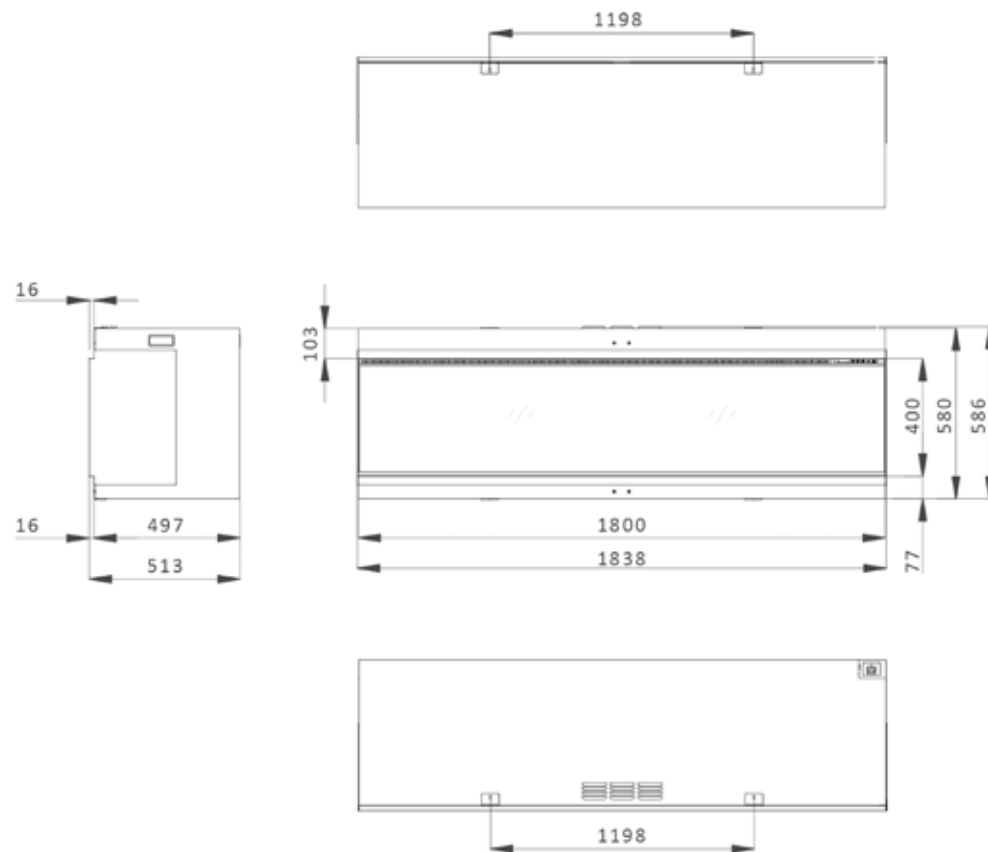
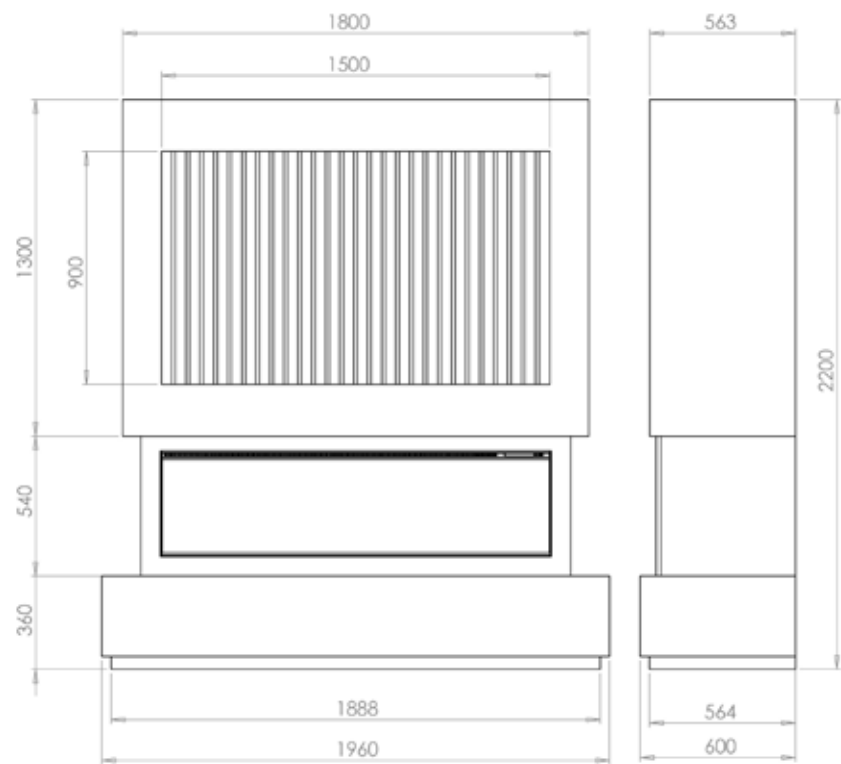

iX APPLIANCE DIMENSIONS.

All dimensions are in millimetres.

iX¹⁸ Panoramic/Corner

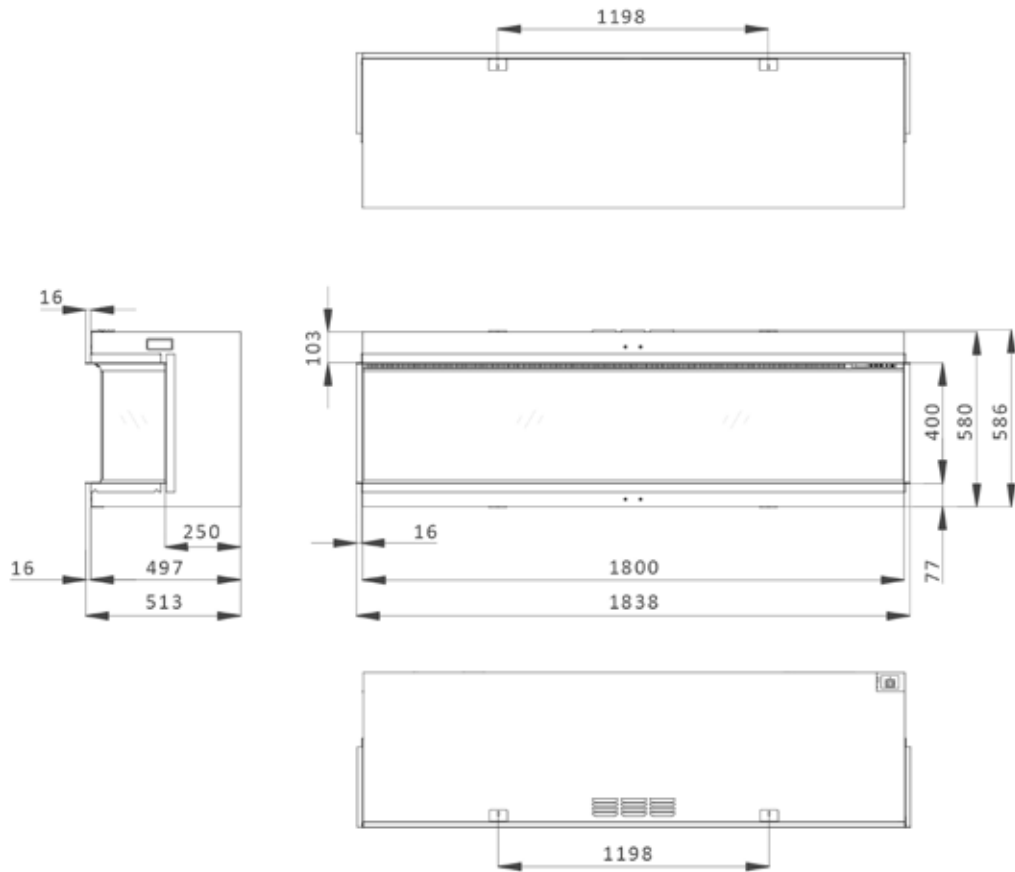

iX¹⁰ Trim (50mm)

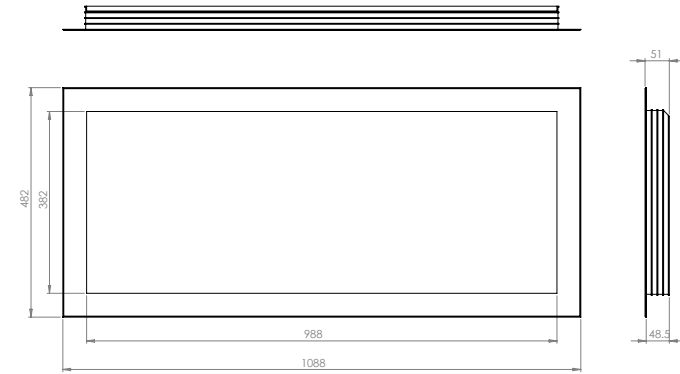

iX¹⁵ Trim (50mm)

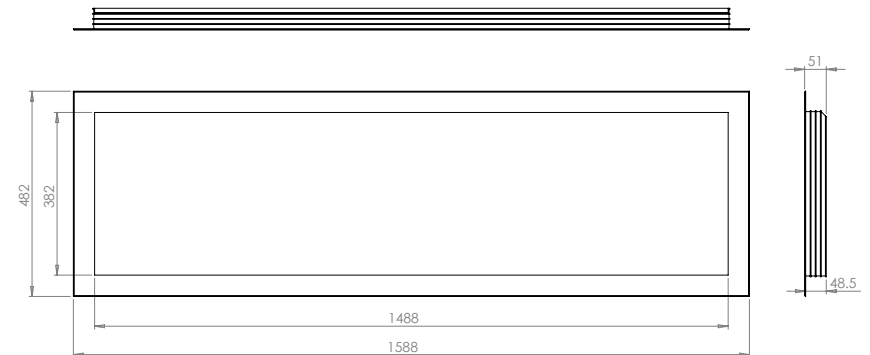

VS APPLIANCE DIMENSIONS.

All dimensions are in millimetres.

VS75

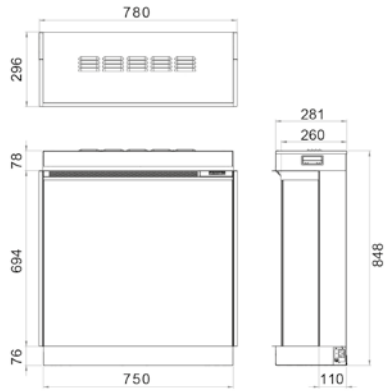

VS100

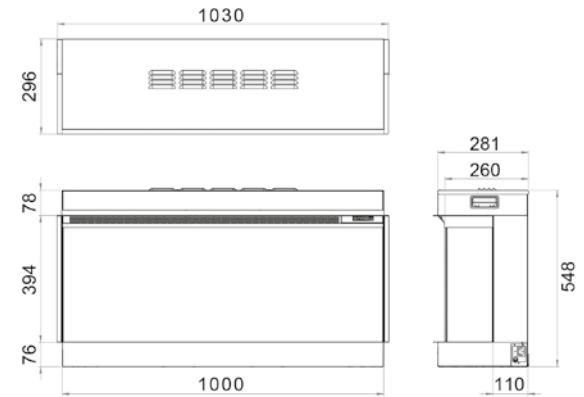

VS100 Nira Suite



VS100 Zenith Suite

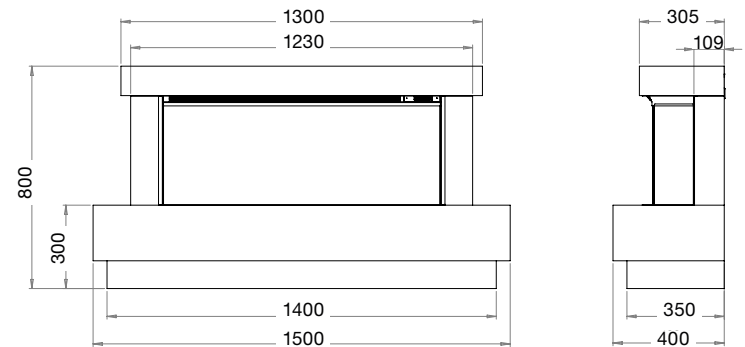

VS APPLIANCE DIMENSIONS.

All dimensions are in millimetres.

VS130

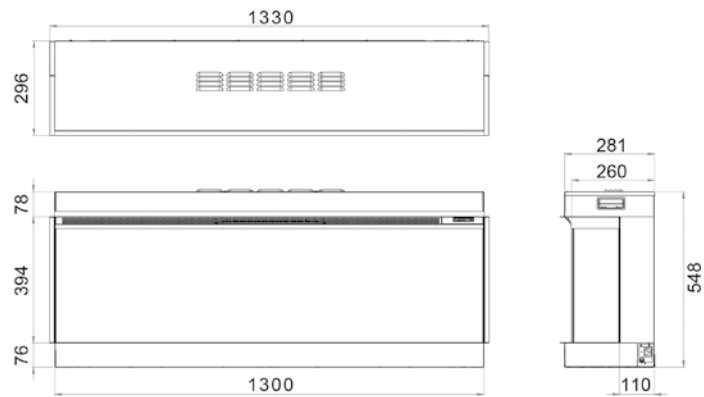

VS150 Media Suite

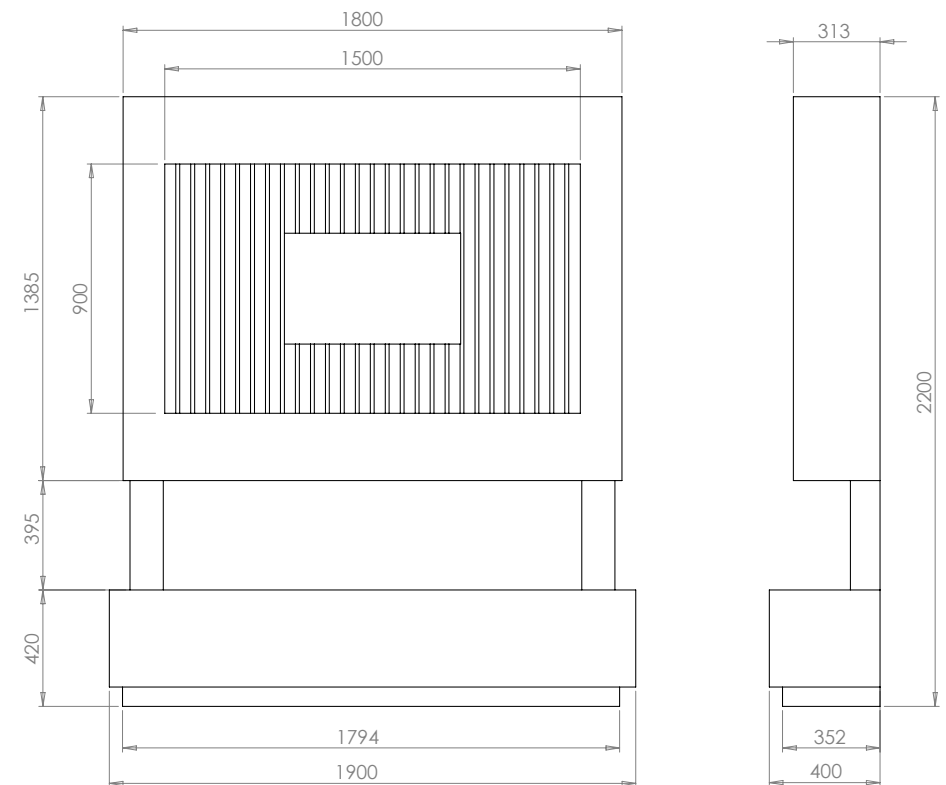

VS150



VS180

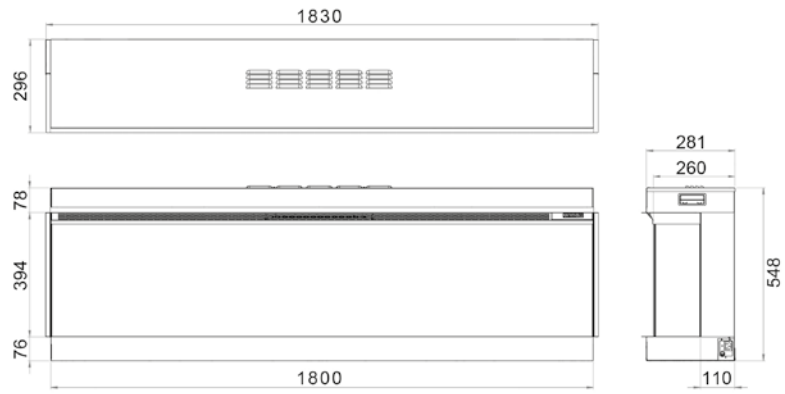

VS220

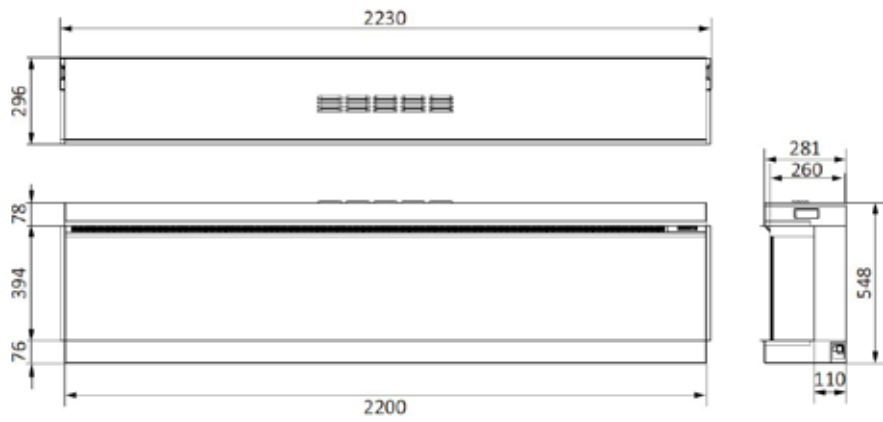

APPLIANCE, PLINTHS & SHELVES DIMENSIONS.

All dimensions are in millimetres.

VS75 Bottom Shelf

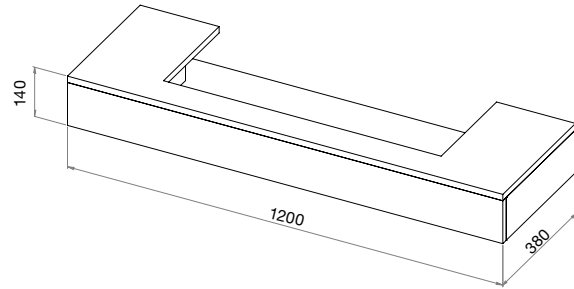

VS75 Floor Plinth

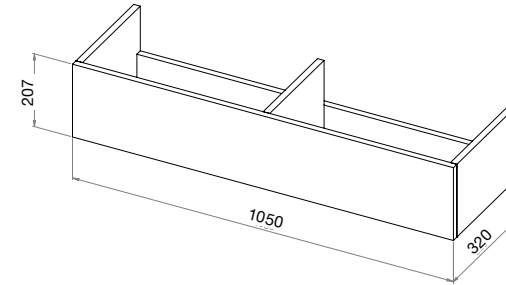

VS100 Bottom Shelf

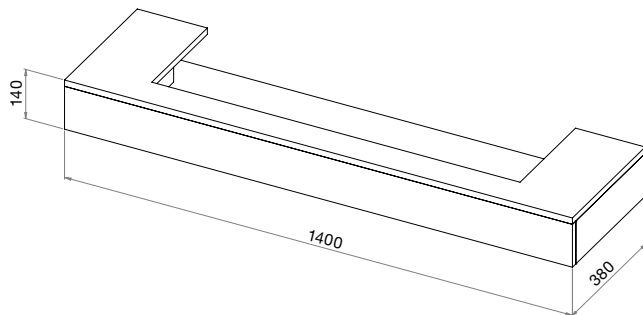

VS100 Floor Plinth

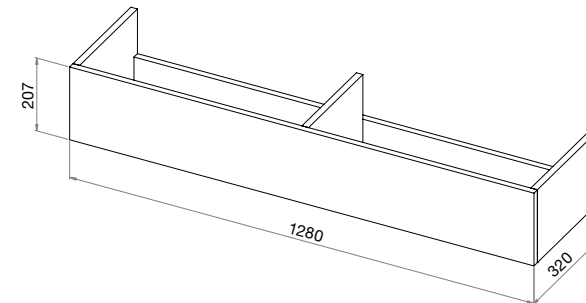

VS100 Top Shelf

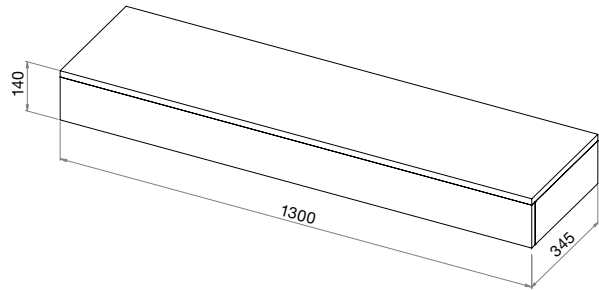

VS130 Bottom Shelf

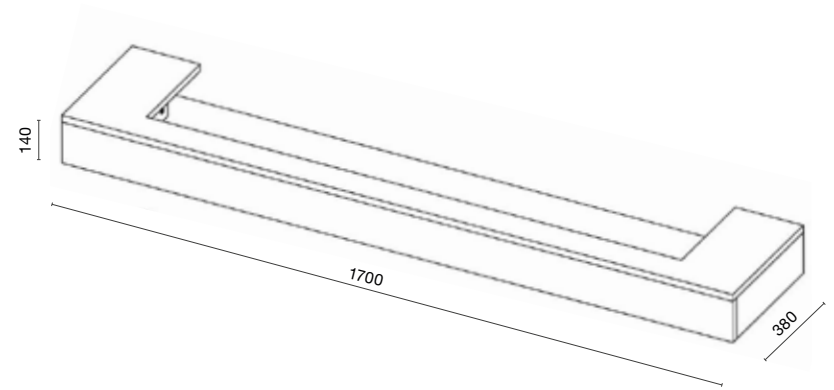

VS150 Bottom Shelf

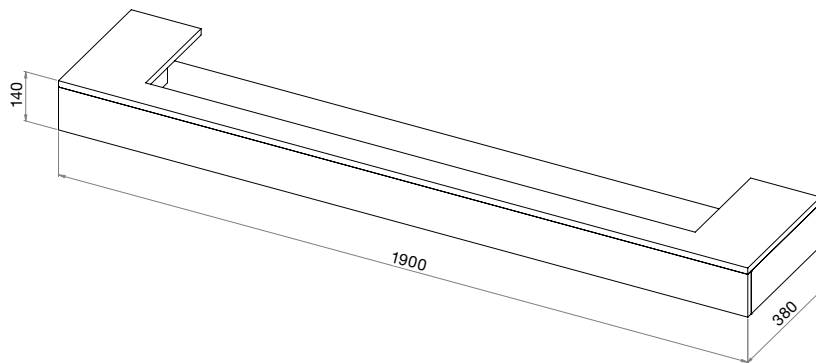

VS150 Floor Plinth

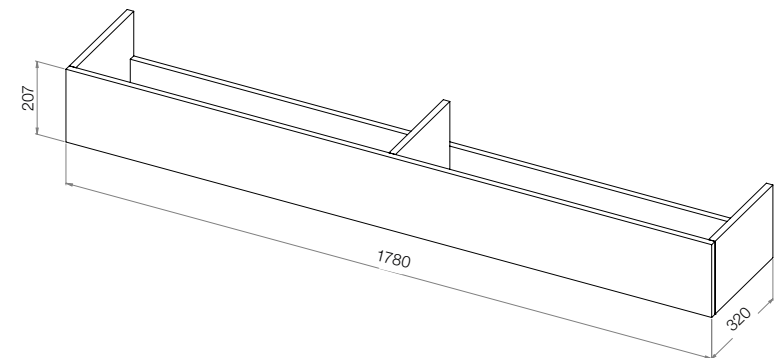

PLINTHS & SHELVES DIMENSIONS.

All dimensions are in millimetres.

VS150 Top Shelf

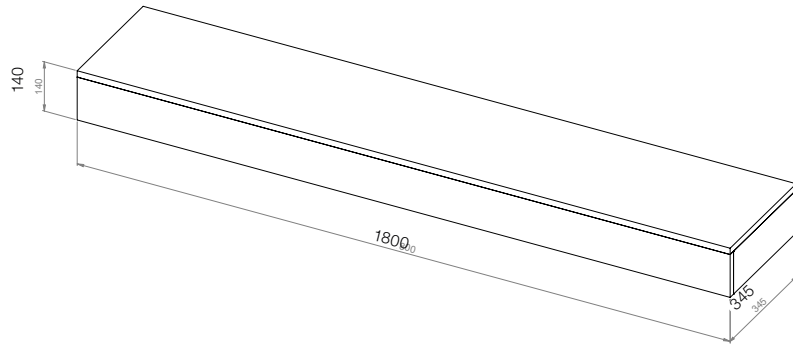

VS150 Canova Plinth

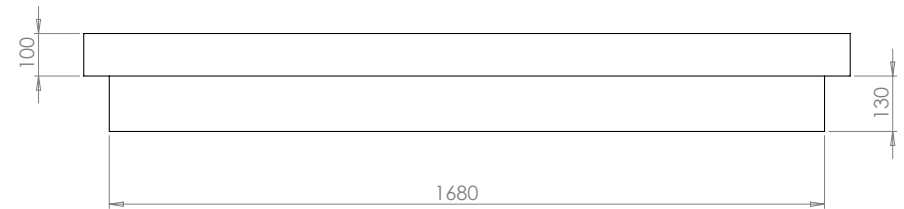
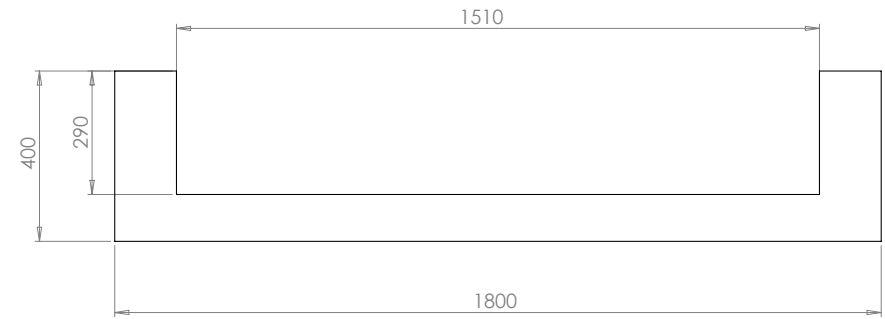



6 YEAR COMPREHENSIVE WARRANTY.

The Solus Collection is built on over 70 years of experience in the fireplace industry, using traditional skills alongside modern design methods to create unique, high quality stylish and functional products. Quality excellence is an integral aspect of all our appliances, our meticulous attention to detail, high standards and quality craftsmanship means you can be confident in choosing a Solus appliance. As standard Solus appliances come with a 6-year warranty (parts & labour) subject to terms and conditions* when purchased through an authorised dealer. Appliances purchased outside of our authorised dealer network will carry a statutory 1-year non-extendable warranty. Details and full terms and conditions can be found at www.visionfires.co.uk Please visit www.visionfires.co.uk/warranty to register your appliance. Find your nearest solus approved stockist at <https://www.visionfires.co.uk/find-a-solus-retailer/>

*Please visit <https://www.visionfires.co.uk/warranty/> for details.

BROCHURE PHOTOGRAPHY.

All the images throughout this brochure are for illustrative purposes only. The colours shown in the brochure are as accurate as possible, however some natural materials may vary due to the nature of the products.

DISCLAIMER.

The brochure was correct at the time of printing, we reserve the right to change or withdraw details, prices, or specifications without prior notice. Every effort has been made to ensure the accuracy of information in this brochure. All dimensions are given for your convenience and should only be used as a guide. Colour reproduction is as accurate as current printing methods allow. We cannot be held responsible for changes or matters outside our control.



2nd Edition **2025**

01204 868 550 | info@visionfires.co.uk | www.visionfires.co.uk